

## Fuel Pump Cam Drive BBC JESEL .400 HI Cam Location Complete Kit Fits JESEL KBD33500

Fuel pump mounting holes can be used with the FPMD (Fuel Pump Magneto Drive) to put the magneto out front and off the top of the engine.

There are two sets of mounting holes to provide a 12 degree offset should it be needed. The offset can go CW or CCW depending which way the front plate is mounted.

The hardened drive pins drive from the JESEL front hub and connect to the adapter hub. The 3/8" hex drive bolts to the adapter hub.

Bolts washers and spacers are provided for a complete installation kit.



**Part Number 39225-33500**

**List Price \$ 495.00+ea**

**Racer Decal Discount \$450.00+**

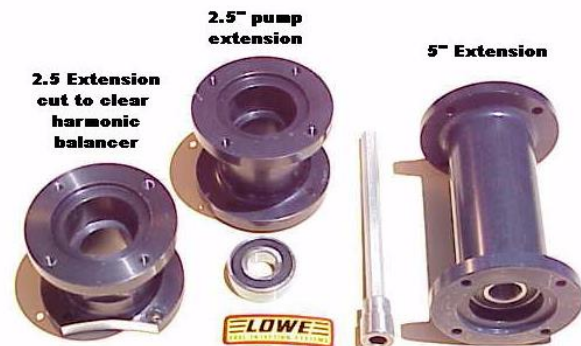

Extension assemblies include bearing and driveshaft



### Other items you may need.....

**Fuel Pump Extensions** – Fuel pump extensions are not a complicated piece of hardware. Their job is to simply move the pump forward to clear the blower belt on some applications or the harmonic balancer in other situations. Or that is where they start, in the design and application process. More considerations come into play once the product is placed in use. In some applications, like non supercharged engines with small fuel pumps, it probably does not make any difference how strong the pump extension is because almost any design will work as long as it meets the rest of the design criteria. Such as, does it have a notch to clear the harmonic balancer and does it prevent oil from leaking between the pump and the end of the extension. Not all pump extensions will do that.



**Extension assemblies include bearing and driveshaft**

In supercharged applications more considerations must be met in the design criteria of the product. Supercharged engines use larger, heavier fuel pumps, and often fuel pump magneto drives. Now the fuel pump extension must carry the larger fuel pump, the offset magneto drive and the magneto. Now all that stuff is getting heavy and you are hanging it out on the end of a flimsy fuel pump extension. How long will that last? Add to this some bad tire shake and you have a fuel pump extension housing failure. Since the magneto is driven through the fuel pump extension, should it fail at an incontinent time it could misfire and cause a blower explosion.

There are three basic different designs for fuel pump extensions.

- \*Three piece billet design
- \*One piece cast design
- \*One piece billet design.



### **Three piece billet design**

The three piece billet design was created to produce a product that can be manufactured with the least amount of material and work thus reducing the cost of the product. The problem is that this design uses 1/4" bolts or smaller in a very small bolt pattern around the tube of the extension to bolt the end pancakes to. This small bolt circle has a limited strength since the top and bottom bolts are usually only about 1 1/4 inch apart. If you hang a big fuel pump, magneto offset drive and a magneto out on the end of a long extension and have some tire shake how long will it take to have a failure here? Remember they are threaded into the aluminum pancakes that form the fuel pump extension flanges which are usually only about 3/8" thick.

### **One piece cast design**

One piece cast design is not very robust and must be much heavier. In today's racing some racers are using more and more overdrive which means larger and larger bottom pulleys and in this situation getting the clearance between the bottom pulley and the fuel pump extension can be a problem.

### **One piece billet design**

Although this design is the most expensive because it requires a lot of machining to remove the material to create the product. Material that costs to purchase initially and then has to be removed to create the product. This design is by far the strongest design. The one piece billet design starts with a solid bar of aluminum and machines off the material that is not needed. A strong and robust design creates a product that the racer will never have a problem with. Although more expensive to manufacture than other designs this is the product that racers use when they do not want failures.

## Design features used in a quality product

A design consideration that is often overlooked by the designer and manufacturers of fuel pump extensions is to insure the engine oil from the front timing cover or gear drive does not leak out. Some do not use a bearing to support the driveshaft and even some of those who do rely on the bearing to hold the oil inside the engine. Unfortunately the oil will seep past the bearing and the shaft or the housing and will leak out. The LOWE Industries fuel pump extension uses both a bearing (with seals to protect the bearing) and a separate seal on the fuel pump driveshaft to seal the oil inside the engine. Most fuel pump extensions do not take this into consideration and racers find that they must put some type of sealer between the fuel pump and the extension to keep the oil from dripping out. There are two problems with this. First is only covering up a design flaw of the fuel pump extension and second if the fuel pump seal should fail in insures that it will not leak onto the ground. There are two problems with this.

As a racer you want know if you fuel pump is leaking as the seal because this means that fuel intended for the engine is not getting there which means a lean condition and also that the fuel instead of leaking onto the ground is now going into the engine and diluting the engine oil, something else you do NOT want.

### Bolt pattern.

There are two different bolt patterns on fuel pumps. Most small pumps have the asymmetrical three bolt pattern while all large pumps have the standard four bolt pattern. This pattern is four 1/4" holes on a 2.75" bolt circle. Our fuel pump extensions are drilled for mounting to the engine with the four holes for three reasons. First four bolts are stronger than three, and the four bolts are symmetrical. Finally the square pattern is more mounting friendly. Where the fuel pump mounts most of our fuel pump extensions have dual pattern. One pattern is the standard symmetrical four hole pattern for the big pumps and the other is the asymmetrical pattern for the small pumps. Most pumps made today have a separate mounting flange that allows the pump to rotate to position the pump where you want it but the older pumps do not have that. We have positioned the three hole asymmetrical pattern to point the pump outlet at the 2o'clock position (as you look at the front of the engine)as this points the pump outlet towards the barrel valve on a supercharged engine. Caution as the lower pump mounting bolt length may be critical as on some applications it may pass through and hit either the crank trigger ring or blower pulley.

### Driveshaft length.

Since our fuel pump extension may be used with other vendors hardware it is important to verify the driveshaft length when installing the fuel pump extension. We will provide you with a driveshaft long enough for most applications and in some applications it may be too long so you may have to remove a little off the end. If it is too short (very rare) let us know and we can supply you with a driveshaft made to the length desired.

## Advantages of LOWE Industries fuel pump extensions

- \*One piece billet makes it the strongest possible design and insures no leaks between bolt together joints.**
- \* Bearing supported drive shaft insures the fuel pump drive will not be subjected to undue stress.**
- \* Inner seal keep the oil inside the engine and any leaking fuel outside the engine.**

Now that the design parameters are out of the way lets discuss application.

The 2.5" extension is usually meant for use on non supercharged engines to get the pump out past the harmonic balancer and in some cases past the crank trigger ring. It can be used in some situations where there is limited clearance



in the front of the engine and the bottom blower pulley is not so large as to get in the way and it allows the pump to sit back slightly inside the blower belt saving room in front of the engine.

The 5" extension is the usual extension for most normal applications. Our billet extension is strong enough we have even had customers cut the bottom out of it so they could run a very big bottom pulley so that the blower pulley just barely cleared the fuel pump driveshaft. Now that is a big pulley.

Small block Chevy's usually use the notched extensions. This is because of the distance between the crank centerline and the cam centerline on this engine. The notch is used to clear the harmonic balancer on a normally aspirated engine (with a 2.5" extension) or the notch is used to clear the blower pulley on a supercharged engine. Not all supercharged engines use a blower pulley large enough to require a notched extension but some do and if you are ever going step up your combination you may need the clearance.

Big block Chevys, Small block Fords and Chrysler Hemi's do not need a notched extension. So far this has been a lot of information about a product that is really quite simple but knowledge is power and we want to give all our customers as much power as possible.



## Four different configurations

- A. 2.5" – no notch – pn 35225-25100
- B. 2.5" – notch – pn 35225-25101
- C. 5" – no notch – pn 35225-50100
- D. 5" – notch – pn 35225-50101

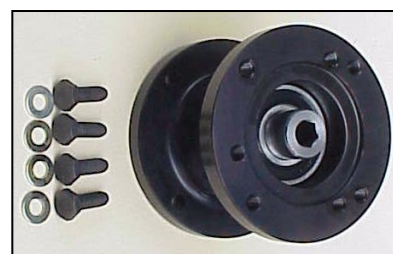

2.5" – no notch – pn 35225-25100	List Price \$ 315.00 +	Racer Decal Discount \$ 275.00 +
2.5" – notch – pn 35225-25101	List Price \$ 335.00 +	Racer Decal Discount \$ 300.00 +
5" – no notch – pn 35225-50100	List Price \$ 345.00 +	Racer Decal Discount \$ 305.00 +
5" – notch – pn 35225-50101	List Price \$ 360.00 +	Racer Decal Discount \$ 330.00 +

## FPMD (Fuel Pump Magneto Drive) 4.8" offset (center to center)

We have been manufacturing offset mag drives for over twenty years and have created several different designs for different applications. Since the blowers have gotten larger and larger, room for the magneto in the conventional location on top of the engine has vanished. All fuel injected race engines have a mechanical fuel pump drive off the camshaft and this provides an excellent power source to drive a magneto as well. Just unbolt your fuel pump and bolt the LOWE FPMD on to your engine or fuel pump extension and then bolt your fuel pump back on to the front of the FPMD. Now install your magneto (SuperMag 1 through 6 or MSD magneto) on to the FPMD mag drive housing using your standard lock clamp. Set your timing and you are done. In standard locations the bottom of the magneto (or distributor) drives the oil pump as well and if you drive the magneto from another power source you must still install a oil pump drive. We have these available as well.

### Features of the LOWE 4.8" FPMD.

- \*Reliable belt drive to the magneto
- \*Triple option for magneto drive with no changes, two pin, four pin or Dunn drive all in one.
- \*4140 fuel pump drive shaft – strong enough to drive the fuel pump and magneto
- \*Dual pattern on mounting flange
- \*Trimmed bottom case to allow offset drive to be moved closer to engine and clear most blower pulleys



**\*Keyway shafts and hubs.**

**\* Seal in the fuel pump drive shaft to keep oil out of belt housing.**

**\*Support mounting holes provided in housing**

**\*Anodized housing for appearance and durability**

**\*Predrilled and tapped fuel pump mount flange**

**\*Full sealed ball bearing design for long life.**

**\*Separate oil seal to prevent engine oil from entering the inside of the belt case.**

**\*Belt tension never needs adjustment.**

**\*Fully enclosed belt drive housing to prevent damage to belt.**

**\*Easy to disassemble to inspect**

**\*All stainless fasteners**

**\*Cable tach drive option**



The 4.8 offset drive has a totally enclosed belt to protect the belt. We allowed the mag drive shaft to be flush with the back of the housing so it can be observed if the mag drive is turning while the engine is cranking to start. This was provided to allow the tuner to troubleshoot problems more easily.

Our unique drive hub insures that your mag drive will fit your mag. Our universal hub has both a two pin and a four pin drive provisions as well as the Dunn drive cross. Slide your mag on and tighten the clamp.

In supercharged applications if you mount the FPMD directly to the front of the engine without using a fuel pump extension the FPMD must sit at the 12 o'clock (or straight up) position. Some conflict with the idler pulley can be a concern. Mounting it this way does limit the diameter of the bottom pulley but it will move the fuel pump back as far as possible which in some cases can be a big benefit as fuel tanks and other chassis hardware may conflict.

Moving the FPMD out to the end of a fuel pump extension allows the FPMD to be installed at any angle desired as the FPMD will sit in front of the blower drive belt. This also removes any conflict with the blower belt idler pulley. Fuel pump extensions for this application must be robust as it must hold the weight of both the fuel pump and the magneto. The LOWE fuel pump extensions come in two lengths 2 1/2" and 5" and also have the option of a notched flange to accommodate applications such as small block Chevys that have a very close crank to cam center line. The fuel pump extension is notched to clear both a harmonic balancer or larger blower pulleys and timing rings. The LOWE fuel pump extensions are CNC machined from one piece billet aluminum and have a bearing supported drive shaft with a seal on the drive hub to keep oil inside the engine and not let it drip out at the end of the pump extension.

The mounting for the offset mag drive to the pump extension or engine is with the standard symmetrical four bolt pattern of 1/4" bolts on 2.75" bolt circle. We provide two sets of mounting holes for two reasons. It offers the customer more options for mounting.

Our offset mag drive housing has been clearance milled housing to give more room in tight positions and clearance milled to allow larger blower pulleys in certain cases.



The LOWE FPMD has two extra 1/4" holes on the top which can be used for either attaching a support bracket to make the mounting more robust or provisions to zip tie the plug wires to go inside the blower belt. All the components are fully cnc machined to exacting standards for the ultimate in fit and finish.



The complete housing is anodized to protect the aluminum as well as improve the appearance.

The fuel pump mounting face is drilled and tapped for a standard symmetrical four bolt pump mounting on a 2.75" bolt circle. This will accommodate all Enderle 110, 990, 1100, 1200 pumps and Hilborn 175 series pumps and all Waterman Big Bertha pumps. We did not provide a three hole asymmetrical bolt pattern like the small pumps as doing so would require us to increase the material on the bottom of the housing where we have removed it for clearance and vary rarely does anyone use the small pumps in a supercharged application.

If you want to use the FPMD in the original distributor location for Chevy applications we provide a drive that doubles as both the oil pump drive as well as a FPMD drive.

**PN 39225-30480 List Price \$ 1375.00 + Racer Decal Discount \$ 995.00 +**

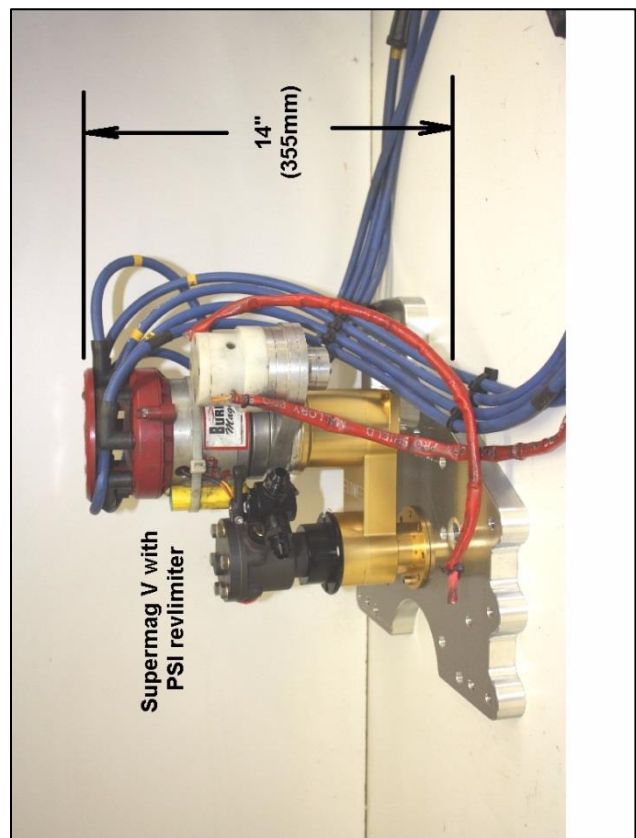
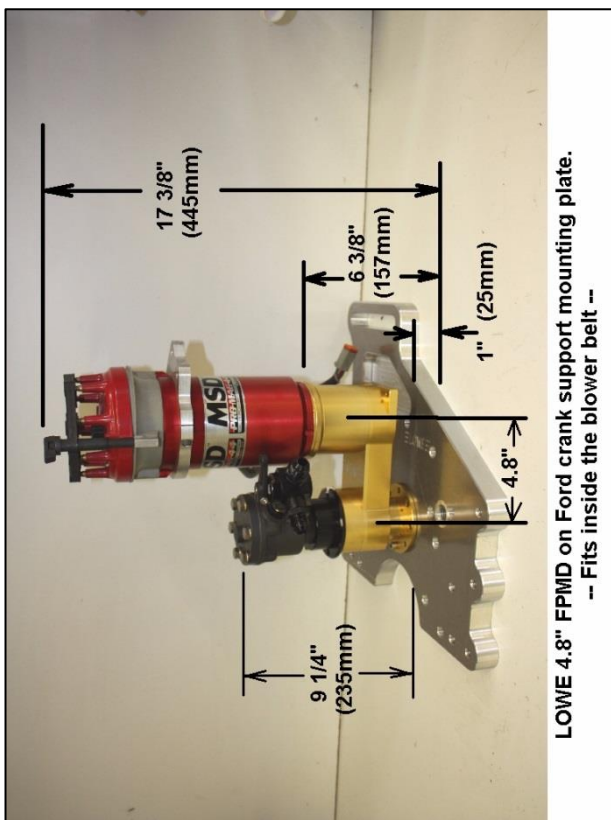

LOWE Race Car Hardware  
Box 180 Rosewood, Q 4340 Australia  
Phone 0411-699 535  
International 01161-411-699 535



[www.KenLowe.com.au](http://www.KenLowe.com.au)

Date \_\_\_\_\_

PLEASE Print Clearly

Purchaser Name \_\_\_\_\_ Billing Address \_\_\_\_\_

City \_\_\_\_\_ State \_\_\_\_\_ Post Code \_\_\_\_\_ Country \_\_\_\_\_

Ship To Name \_\_\_\_\_ Ship To Address \_\_\_\_\_

City \_\_\_\_\_ State \_\_\_\_\_ Post Code \_\_\_\_\_ Country \_\_\_\_\_

Email Address \_\_\_\_\_ Phone Number \_\_\_\_\_

Product(s) I wish to purchase.

1. \_\_\_\_\_

2. \_\_\_\_\_

3. \_\_\_\_\_

4. \_\_\_\_\_

5. \_\_\_\_\_

6. \_\_\_\_\_

7. \_\_\_\_\_

8. \_\_\_\_\_

Credit Card Details \_\_\_\_\_ - \_\_\_\_\_ - \_\_\_\_\_ - \_\_\_\_\_ Expiry Date \_\_\_\_\_ CVV \_\_\_\_\_

Printed Name \_\_\_\_\_

Signature \_\_\_\_\_

Preferred shipping method \_\_\_\_\_

Instructions: Please fill this out completely, scan it and email it back to **Ken@KenLowe.com.au**  
Prices of product do not include any shipping or taxes. Prices are subject to change and must be verified at time of order. In order to receive the Racer Decal Discount pricing purchaser agrees to display the LOWE stickers (10cm x 30cm) on both sides of vehicle the products are being used on.